



AEROLEDs™

Installation Instructions Sunspot 46-4000 series



AeroLEDs, LLC
8475 W. Elisa St.
Boise, ID, 83709
208-850-3294

NOTE: A printed copy of this document may not be the latest revision. It is the responsibility of the user to ensure that the latest revision is used. The latest revision of this document may be printed from the AeroLEDs electronic document repository. Revision history follows on page 2

This document contains proprietary information of AeroLEDs. Neither receipt nor possession thereof confer any right to reproduce or use, or disclose, in whole or in part, any such information without written permission from AeroLEDs.

Approval	Name	Intent	
Author	Jennifer Blanchfield	Installation and Operation Instructions for the Sunspot 46-4000 series lights	
Check	Nate Calvin		
Quality	Mark McCormack		
Date:	20 July 2023		
Status: Release	Typed signatures indicate approval. Handwritten, or electronic signature approval of this document is on file at AeroLEDs, Boise, Idaho.	Document Number 0107-0004	Revision J

REVISION RECORD

Rev	Description	Date	Author
J	Updating Logo, wiring diagrams, and information add	07/20/2023	J. Blanchfield
I	Updating ICA, Information and table adds	11/6/2020	J. Blanchfield
H	Add 4582 light information	11/4/2020	J. Blanchfield
G	Add 4522 light information	10/20/2020	J. Blanchfield
F	Add Airworthiness limitations	08/10/2020	M. McCormack
E	Format, Instruction, and Image updates	04/13/2020	J. Blanchfield
D	All Pages Revised	05/07/2018	D. Wilkinson
C	All Pages Revised	02/12/2018	D. Wilkinson
B	1 (limitations)	04/25/2017	D. Wilkinson
A	All Pages Revised	09/12/2016	D. Wilkinson
IR	Initial Revision	08/30/2016	D. Wilkinson

TABLE OF CONTENTS

1	System Description	4
2	Model Numbers	4
2.1	Modes of operation (-H lights only).....	4
2.2	Current consumption per input	4
3	Airworthiness Limitations	5
3.1	Instructions for Continued Airworthiness	5
4	Installation	5
4.1	Installation Procedures	6
4.2	Troubleshooting	7
5	Wiring Diagrams	8
5.1	Wiring Diagram for Single Sunspot without Pulse	8
5.2	Wiring Diagram for Single Sunspot with Pulse	8
5.3	Wiring Diagram for Dual SunSpots with Pulse.....	9
5.4	Wiring Diagram for Four LED SunSpots with Pulse.....	10

1 System Description

SunSpot™ 46 4000 series Landing and Taxi lights are designed as LED drop-in replacements for existing PAR46 light configurations. The SunSpot™ 46 is a two terminal light, with the -H versions including additional wires for integrated Pulse/WigWag mode to significantly increase recognition.

2 Model Numbers

Model	Part Number	Description	Voltage (V)	Current (Amps)	Weight (oz)
SunSpot 46-4522	01-2230-4522	Landing	14	10.2	20
	01-2230-4522-H	Landing w/Pulse			
SunSpot 46-4554	01-2230-4554	Taxi	28	6.3	
	01-2230-4554-H	Taxi w/Pulse			
SunSpot 46-4580	01-2230-4580	Landing			
	01-2230-4580-H	Landing w/Pulse			
SunSpot 46-4582	01-2230-4582	Flood			

Table 1

2.1 Modes of operation (-H lights only)

Excluding 01-2230-4522-H

Mode	Switch Position	Mode	Switch Position	Function
Pulse	Open	Landing	Open	Light OFF
	Open		Closed	Landing
	Closed		Open	Pulse
	Closed		Closed	Pulse

Modes of operation (01-2230-4522-H Only)

Mode	Switch Position	Mode	Switch Position	Function
Pulse	Open	Landing	Open	Light OFF
	Open		Closed	Landing
	Closed		Open	Light OFF
	Closed		Closed	Pulse

Note: Refer to §5 Wiring Diagrams

Table 2

2.2 Current consumption per input

Model	Part Number	Modes	Inputs				
			PWR 14VDC*	GND	YLW	BLU	GRN
SunSpot 46-4522	01-2230-4522	Landing Only	10.2A	10.2A	NA		
	01-2230-4522-H	Landing Mode	10.2A		NA	≤10mA	
		Pulse Mode	10.2A		≤10mA		
			28VDC*				
SunSpot 46-4554	01-2230-4554	Taxi Only	6.3A	6.3A	NA		
	01-2230-4554-H	Landing Mode	6.3A		NA	≤10mA	
		Pulse Mode	NA		6.3A		
SunSpot 46-4580	01-2230-4580	Taxi Only	6.3A		NA		
	01-2230-4580-H	Landing Mode	6.3A		NA	≤10mA	
		Pulse Mode	NA		6.3A		
SunSpot 46-4582	01-2230-4582	Flood Only	6.3A	NA			

*Nominal

Table 3

3 Airworthiness Limitations

The Airworthiness Limitations section is FAA approved and specifies maintenance required under **14 CFR, §43.16** and **14 CFR, §91.403** of the Federal Aviation Regulations unless an alternative program has been FAA approved. There are no additional airworthiness limitations.

3.1 Instructions for Continued Airworthiness

Sunspot series LED landing or taxi light assembly contains no user serviceable items. Should any LED fail, unit must be replaced.

Interval	Inspection	Remedy	Notes
Pre-Flight	<ul style="list-style-type: none"> Perform a functional check and observe that all LEDs are illuminated 	<ul style="list-style-type: none"> If all LEDs are not illuminated replace light as soon as is practicable 	<ul style="list-style-type: none"> Lights are not user serviceable. Lights are very bright and to reduce eye strain during inspection use an optical filter such as dark glasses or welding goggles.
Annually, unless the OEM specifies a shorter interval	<ul style="list-style-type: none"> Perform a functional check and observe that all LEDs are illuminated Check mounting, connections, and wire integrity 	<ul style="list-style-type: none"> If all LEDs are not illuminated, the light must be replaced Adjust or replace wiring, and connectors as required 	

Table 4

4 Installation

Consult **14CFR, §43.13-1B** for guidance on acceptable methods, techniques, and practices. Mount in approved bulb holder. For retrofit installation existing circuit breaker or fuse may

typically be used. Procedures contained herein are not intended to conflict with procedures set forth by aircraft OEM, nor do they supersede FAA approved manuals and FAA regulations.

4.1 Installation Procedures

1. Reference the airframe manufacturer's maintenance manual to complete the following steps
2. If the AeroLEDs light(s) chosen for installation are higher wattage than the light(s) being removed, ensure the Electrical Load is not appreciably affected and ensure that all circuit components (circuit breaker, wire, switches, relays, etc., as applicable) are appropriate for the light(s) being installed
3. Prepare aircraft for maintenance:
 - a. Disconnect aircraft power and ground
 - b. Ensure all switches are in the OFF position
 - c. Attach maintenance warning tags
 - d. Pull landing/taxi light circuit breakers
 - e. Remove light covers to gain access to lamp assembly(s) and bracket(s)
 - f. Remove existing lamp(s) from brackets, mark and retain hardware
 - g. Record weight of removed lamps
4. This installation procedure is for single or multiple light installations. Wiring diagrams are provided for single, dual, and quad light installations. For lights without pulse, existing aircraft wiring, switches and breakers may be utilized.
5. **Versions with Pulse:** Pulse function is a self-contained feature and does not require use of external control circuitry. An additional wire, switch, or switch position will be required to enable pulse mode, and for multiple lights an additional synchronization wire installation will be required.
6. Refer to aircraft manufacturer's service manual and/or illustrated parts catalog to identify landing and/or taxi light system installed in your aircraft. This will provide information on location of components and assembly details
7. Mount LED light with a minimum 4-inch clearance to exhaust system components unless adequate heat shielding is utilized to block radiant heat.
8. Reference airframe manufacturer's current maintenance manual and install LED light(s) in brackets using retained hardware
9. Ensure alignment key is fitted to bracket
10. Install suitable aircraft approved connectors or splices to connect landing light assemblies to wires routed from switch in accordance with wiring diagram(s).
11. **Screw terminals are not polarity sensitive.**
 - a. Yellow wire is used to power pulse mode (see **Table 3**)
 - b. Blue and green wires are low current signals for synchronization in two and four light installations (see **Table 3**)
 - c. Install an appropriate aircraft approved switch and circuit breaker of correct rating for lights installed for pulse function. Original landing light switch/switches may be used.
12. Placard switches appropriately.
13. Verify proper operation of LED light(s), in both pulsing and steady functions (as appropriate to installation)
14. Using appropriate aircraft maintenance manual, verify light angle has not changed, and is oriented & aimed in accordance with manufacturer's instructions
15. Reinstall associated light hardware IAW aircraft maintenance manual
16. Perform an operational check of the light(s) to determine that the installed light(s):

- a. Generate no objectionable glare to the pilot
 - b. Do not adversely affect the pilot by halation
 - c. Provide enough light for night operations, including hovering and landing
 - d. Will not adversely affect any installed systems or equipment with EMI/RFI interference
17. Record installation with appropriate logbook entry

Note: The use of shielded cable is recommended although not required for installation.

It is recommended that ground connections for all lights be made at a single location on aircraft central ground bus. This “single point ground” scheme helps to eliminate ground loops and ground bounce that can occur when using airframe as a ground.

4.2 Troubleshooting

If light is not functioning properly, not fully powering up, or not staying powered on, try the following steps to correct problem:

- a. Check for proper voltage at power input wire to light
- b. Ensure light is adequately grounded
- c. Check for continuity in wiring and connections
- d. If wiring is verified, remove light and bench-check with appropriately sized power supply

If above actions do not correct problem, contact AeroLEDs tech support at 1-208-850-3294 for a resolution.

5 Wiring Diagrams

5.1 Wiring Diagram for Single Sunspot without Pulse

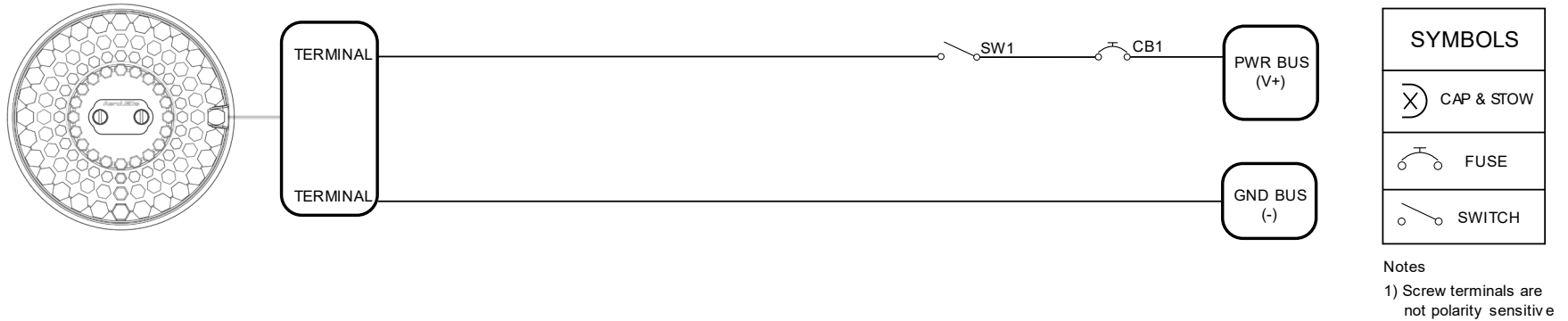

Figure 5-1

5.2 Wiring Diagram for Single Sunspot with Pulse

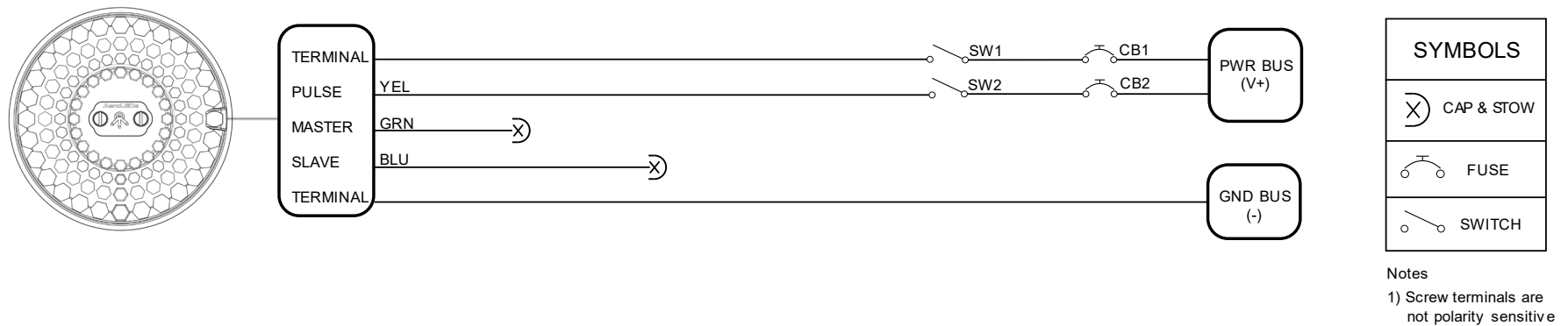

Figure 5-2

5.3 Wiring Diagram for Dual SunSpots with Pulse

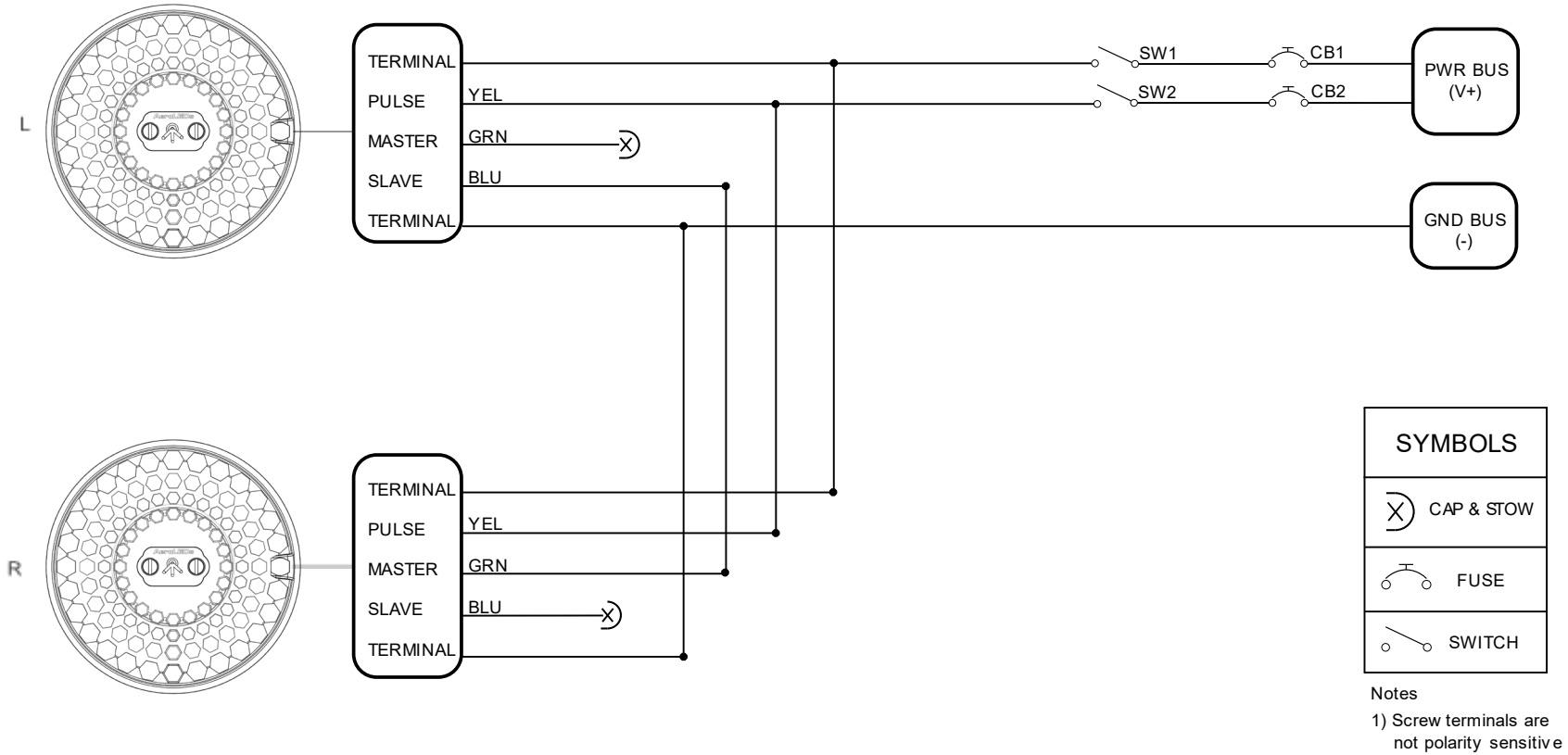

Figure 5-3

If lights are installed in close proximity (within two feet), install using an AeroLEDs sync circuit

- AeroLEDs part number 00-8120
- Installation Guide 0017-0002

5.4 Wiring Diagram for Four LED SunSpots with Pulse

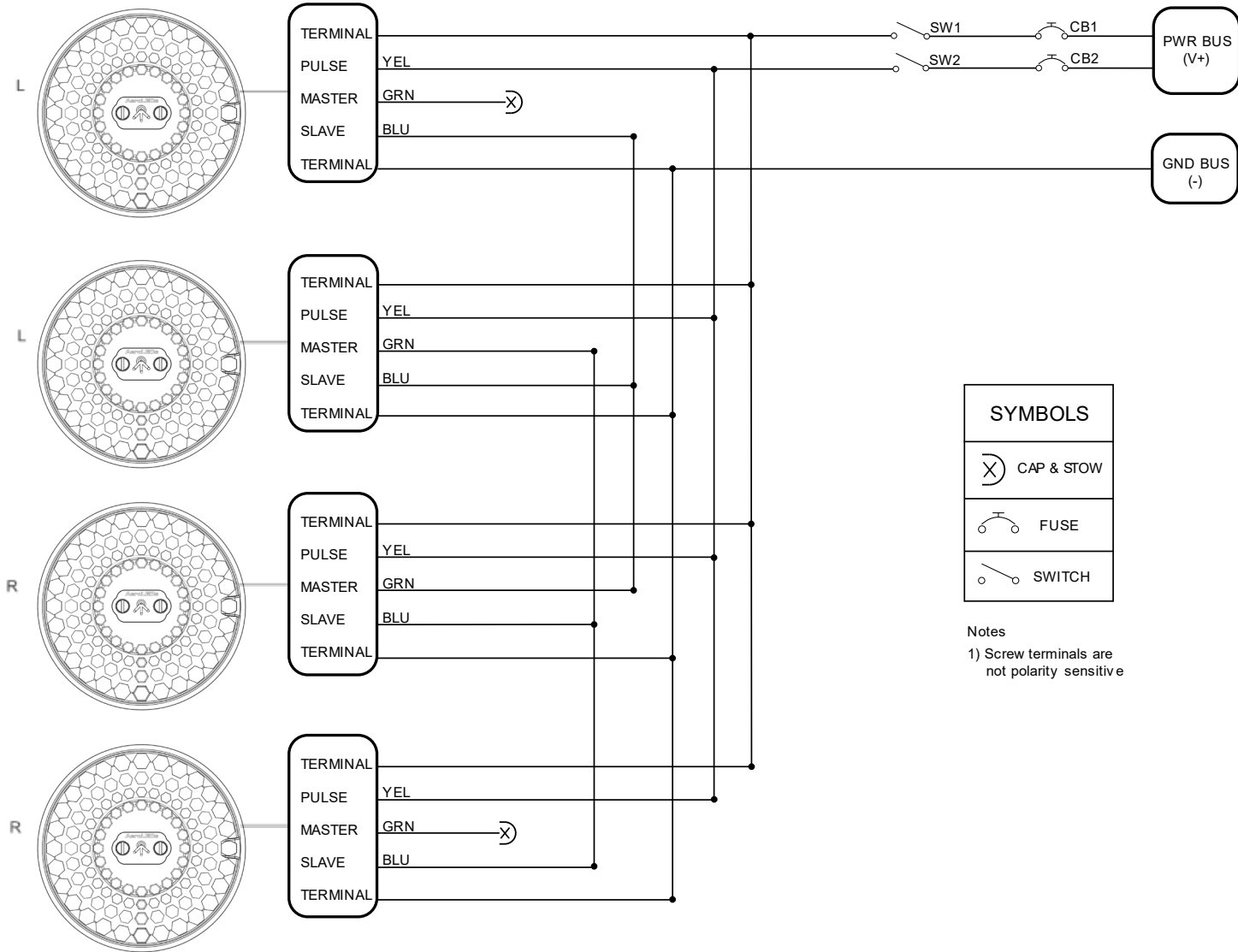

Figure 5-4