



## Installation Instructions

### SunBeam Landing Light



AeroLEDs, LLC  
 8475 W. Elisa St.  
 Boise, ID, 83709  
 208-850-3294

**NOTE:** A printed copy of this document may not be the latest revision. It is the responsibility of the user to ensure that the latest revision is used. The latest revision of this document may be printed from the AeroLEDs electronic document repository. Revision history follows on page 2

This document contains proprietary information of AeroLEDs. Neither receipt nor possession thereof confer any right to reproduce or use, or disclose, in whole or in part, any such information without written permission from AeroLEDs.

Approval	Name	Intent	
Author	Mirelle DeSpain	Installation and operation instructions for the SunBeam landing light (90-1000)	
Check	Robert Prew		
Quality	Mike D'Amico		
Date:	30 July 2019		
<b>Status:</b> Released	Typed signatures indicate approval. Handwritten, or electronic signature approval of this document is on file at AeroLEDs, Boise, Idaho.	<b>Document Number</b> 0013-0014	<b>Revision</b> D



# REVISION RECORD

Rev	Description	Date	Author
C	Updated formatting	07/30/2019	M. DeSpain
B		10/02/2018	R. Prew
A		10/07/2016	D. Wilkinson
IR	Original Version	04/02/2012	D. Wilkinson

## TABLE OF CONTENTS

<b>1</b>	<b>Limitations and Warnings .....</b>	<b>3</b>
1.1	Equipment Limitations .....	3
1.2	Airworthiness Limitations .....	3
1.3	Instructions for Continued Airworthiness .....	3
1.4	Installation Procedures.....	3
<b>2</b>	<b>Wiring Diagrams.....</b>	<b>5</b>
2.1	Wiring Diagram for Single SunRay Plus Landing Light.....	6
2.2	Wiring Diagram for Dual SunRay Plus Landing Lights .....	7
2.3	Wiring Diagram for Four SunRay Plus Landing Lights .....	8



# 1 Part Number Matrix

Table 1-1: Applicable Part Numbers

Part Number	Description
90-1000	Landing light with built-in pulse recognition mode

## 2 Specifications

<b>Operational Voltage:</b>	Separate 9 to 40 V <sub>DC</sub> Systems
<b>Input Current:</b>	2.4 A at 14 V, 1.2 A at 28 V

## 3 Limitations and Warnings

### 3.1 Equipment Limitations

3.1.1 Mount to bezel mounting plate with circuit breaker or fuse appropriate for rated current. The procedures contained herein are not intended to conflict with the procedures set forth by aircraft and engine manufacturers, nor do they supersede the FAA approved manuals and FAA regulations. If necessary, consult **AC 43.13-1B** for guidance on acceptable methods, techniques, and practices.

### 3.2 Airworthiness Limitations

3.2.1 The Airworthiness Limitations section is FAA approved and specifies maintenance required under sections 43.16 and 91.403 of the Federal Aviation Regulations unless an alternative program has been FAA approved. There are no new (or additional) airworthiness limitations associated with this equipment and/or installation.

### 3.3 Instructions for Continued Airworthiness

3.3.1 The SunBeam LED landing light assembly is designed with 6 high power LEDs mounted behind a lens. Should any one LED fail, the unit must be replaced.

3.3.2 Lights are not field repairable and should be sent to manufacturer for repair/replacement if defective.

Interval	Description
50 hr.	<ul style="list-style-type: none"><li>• Perform functional check on landing light(s) and replace unit if defective</li></ul>
100 hr.	<ul style="list-style-type: none"><li>• Perform functional check on landing light(s) and replace unit if defective</li><li>• Inspect for discoloration of lens</li><li>• Inspect mounting for security</li><li>• Inspect all connectors for good engagement</li><li>• Inspect wiring for chaffing / defects</li></ul>
Annually	--SAME AS 100 HOUR--

### 3.4 Installation Procedures

3.4.1 The installation procedure described in the following text is for a single light installation, but the procedure is identical for multiple light installations. The pulsing function of the replacement landing light(s) is a self-contained feature and does not require the use of an externally mounted pulse light controller.

3.4.2 Remove cowlings and/or landing light lens to gain access to light assemblies.

- 3.4.3 Route 3-conductor shielded wire (minimum 20 AWG) from switch location to LED landing light assemblies through wings and/or cowling, securing wire bundles as needed using tie-wraps or equivalent means.
- 3.4.4 Install suitable aircraft approved connectors to wires coming from landing light assemblies and wires routed from switch using the wiring diagrams in section 4.
- 3.4.5 Mount a suitable mounting plate with appropriate cutout and mounting holes for bezel mounting the light in the desired location and aimed in the desired direction.
- 3.4.6 Install an appropriate aircraft approved switch and circuit breaker of correct rating for the lights installed for the pulse function. Original landing light switch/switches may be used, but the circuit breakers are to be replaced with one(s) of appropriate rating for the lights installed.
- 3.4.7 Placard switches appropriately.
- 3.4.8 Power up aircraft and verify proper operation of SunBeam LED light, in both pulsing and steady functions (as appropriate to the installation)
- 3.4.9 Using the appropriate aircraft maintenance manual, verify that the light angle has not changed, and is oriented & aimed in accordance with manufacturer's instructions.
- 3.4.10 Perform EMI test to verify there is no interference caused by light installation.
- 3.4.11 Reinstall cowlings or lens covers as needed.
- 3.4.12 Fill out and submit appropriate form 337 for work accomplished (unless installed under STC or installed in an experimental or LSA), and enter appropriate logbook entry detailing work.
- 3.4.13 Determine weight & balance change, and update aircraft weight and balance data.

# 4 Installation and Wiring Diagrams

## 4.1 Mounting Diagram

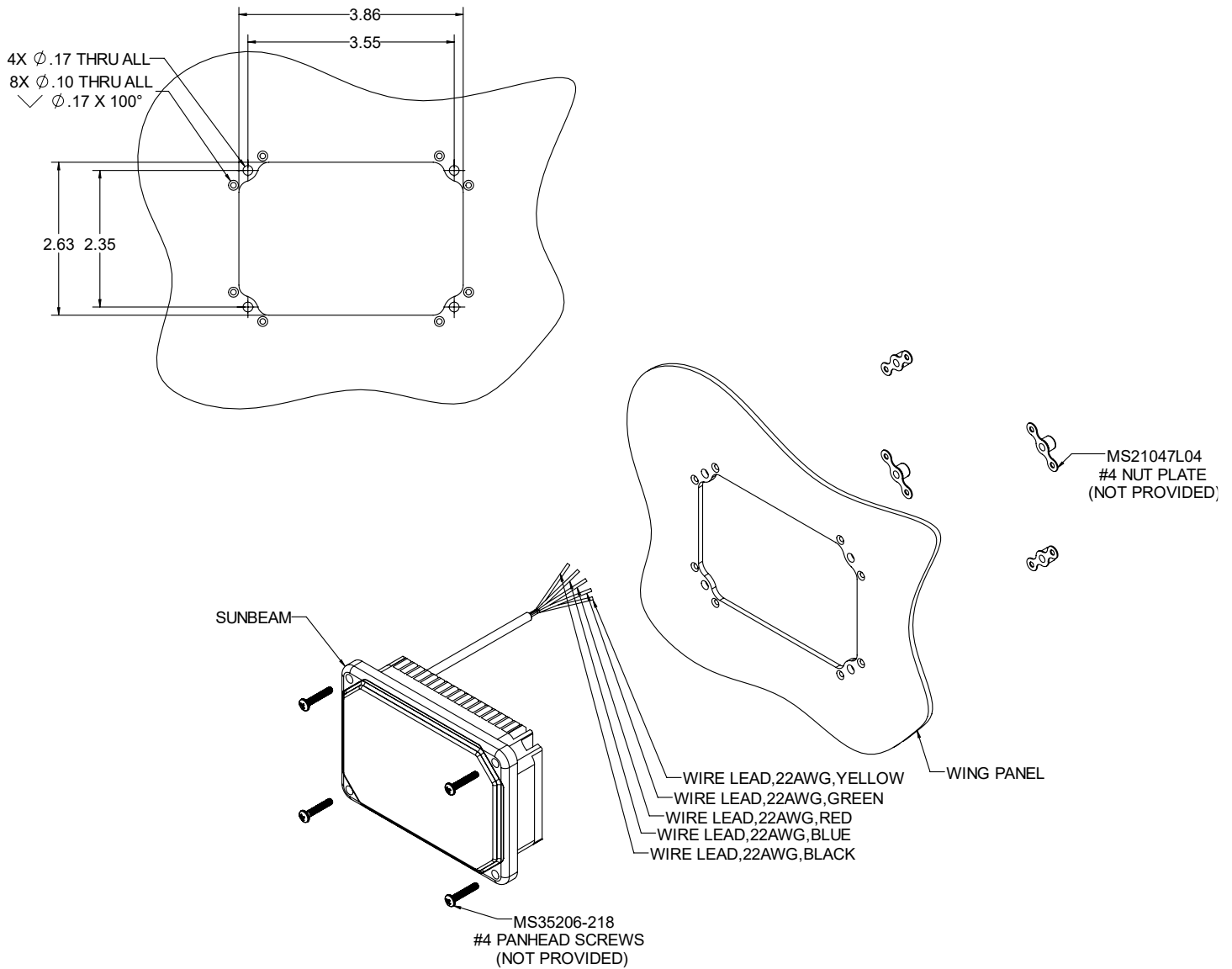

Photo 4-1

## 4.2 Wiring Diagram for Single SunBeam Landing Light

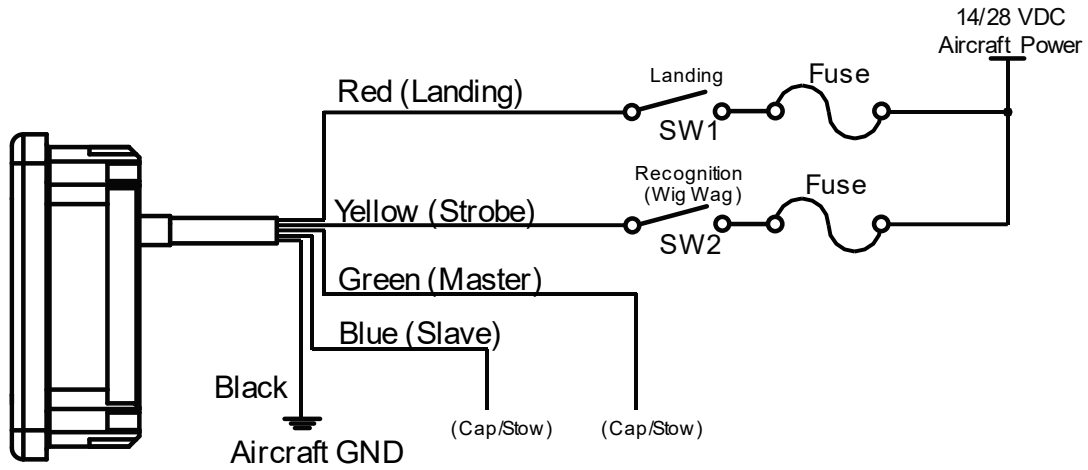

Photo 4-2

- 4.2.1 Recommended fuse size for each switch is 3 A.
- 4.2.2 Recommended wire size is 22 AWG.

### 4.3 Wiring Diagram for Dual SunBeam Plus Landing Lights

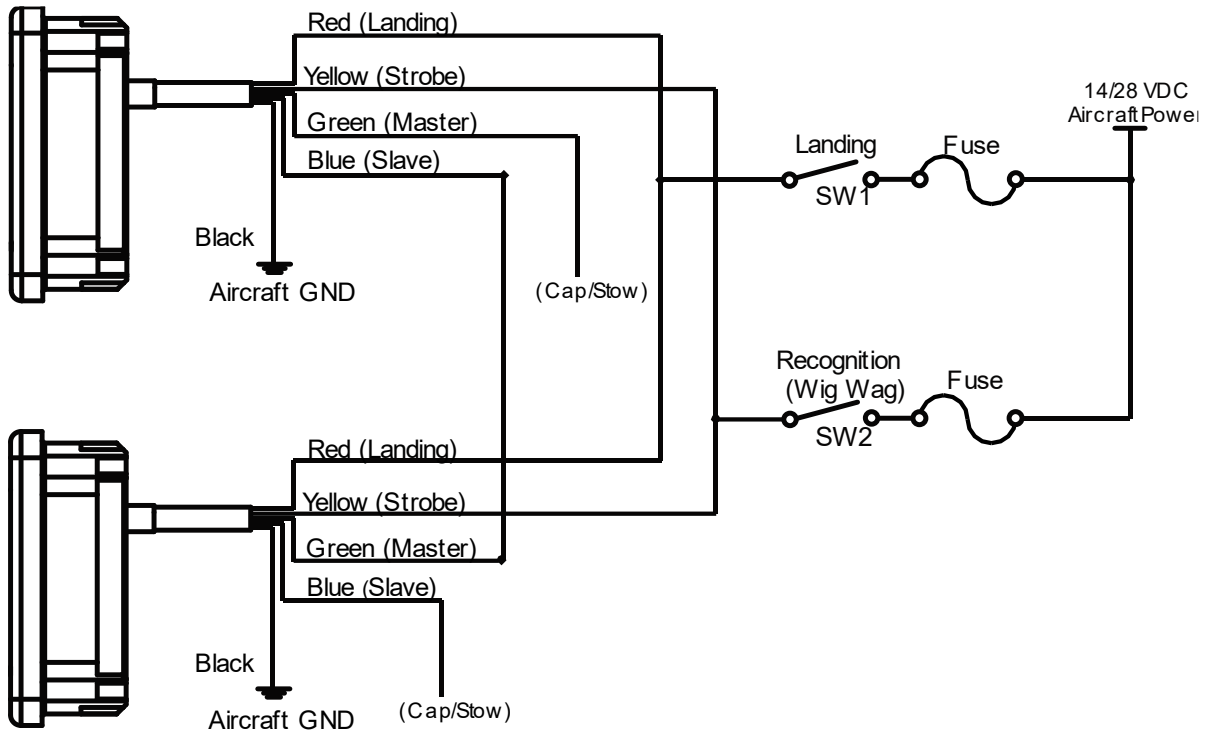
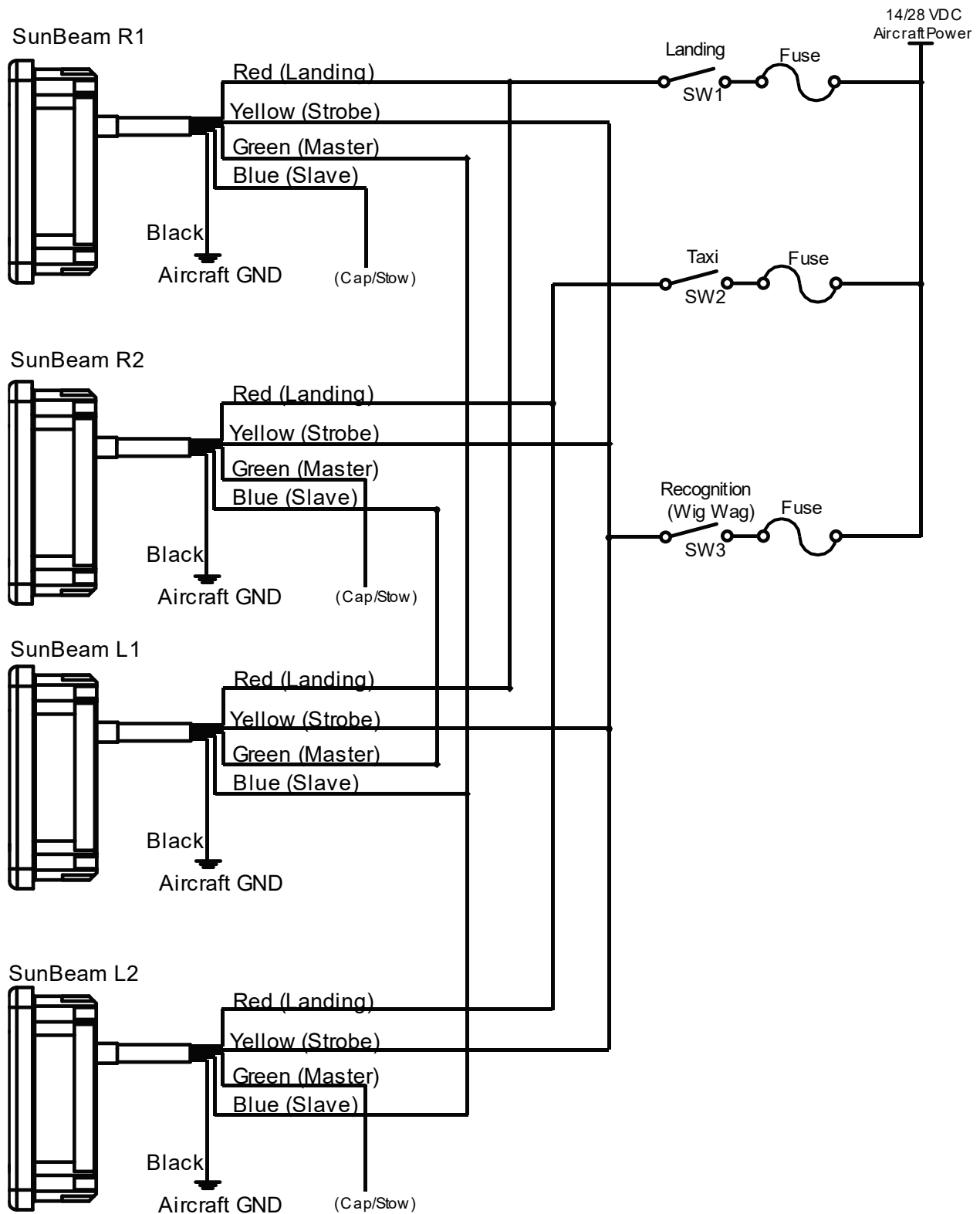

Photo 4-3

- 4.3.1 Recommended fuse size for each switch is 5 A.
- 4.3.2 Recommended wire size is 20 AWG.

## 4.4 Wiring Diagram for Four SunBeam Landing Lights



**Photo 4-4**

- 4.4.1 Recommended fuse size for the taxi and landing switches is 5 A.
- 4.4.2 Recommended fuse size for the recognition switch is 10 A.
- 4.4.3 Recommended wire size is 18-20 AWG.



DO-160E Section	Compliance Level
4	F2
5	F2
6	C
8	U
9	H
10	S
11	F
12	D
13	F
14	S
15	A
16	Z
17	A
18	Z
19	ZC
20	RR
21	H
22	A2E2

