



Pulsar NS Installation Instructions



AeroLEDs, LLC
 8475 W. Elisa St.
 Boise, ID, 83709
 208-850-3294

NOTE: A printed copy of this document may not be the latest revision. It is the responsibility of the user to ensure that the latest revision is used. The latest revision of this document may be printed from the AeroLEDs electronic document repository. Revision history follows on page 2

This document contains proprietary information of AeroLEDs. Neither receipt nor possession thereof confer any right to reproduce or use, or disclose, in whole or in part, any such information without written permission from AeroLEDs.

Approval	Name	Intent	
Author	Robert Prew	Installation instructions for the certified Pulsar NS series lights (11-1280-A/B/C)	
Check	Nate Calvin		
Quality	Mike D'Amico		
Date:	September 19 2019		
Status: Released	Typed signatures indicate approval. Handwritten, or electronic signature approval of this document is on file at AeroLEDs, Boise, Idaho.	Document Number 0008-0006	Revision A



REVISION RECORD

Rev	Description	Date	Author
A	Updated	09/19/2019	R. Prew
IR	Original Version	12/06/2016	D. Wilkinson

TABLE OF CONTENTS

1	Part Number Matrix	3
2	Specifications	3
3	Limitations	3
3.1	Equipment Limitations	3
3.2	Airworthiness Limitations	4
3.3	Instructions for Continued Airworthiness	4
3.4	Installation Procedures	4
4	Installation and Wiring Diagrams	5
4.1	Mounting Diagram	5
4.2	Installation Template	6
4.3	Wiring Diagram.....	6
4.4	Fuse Selection.....	7





The conditions and tests required for TSO approval of this article are minimum performance standards. It is the responsibility of those installing this article either on or within a specific type or class of aircraft to determine that the aircraft installation conditions are within the TSO standards. The article may be installed only if performed under 14 CFR part 43 or the applicable airworthiness requirements.

Forward Position Lights: TSO C-30c Type I and Type II
Rear Position Light: TSO C-30c Type III
Anti-collision Strobe: TSO C-96a Class II

Deviations: Tested to DO-160E as called out in TSO-C-30c and TSO C-96a

1 Part Number Matrix

Table 1-1: Applicable Part Numbers

Part Number	Description
11-1280-A-12-L	Navigation light – 12V _{DC}
11-1280-A-12-R	Navigation light – 12V _{DC}
11-1280-A-24-L	Navigation light – 24V _{DC}
11-1280-A-24-R	Navigation light – 24V _{DC}
11-1280-B-12-L	Navigation and anti-collision lights – 12V _{DC}
11-1280-B-12-R	Navigation and anti-collision lights – 12V _{DC}
11-1280-B-24-L	Navigation and anti-collision lights – 24V _{DC}
11-1280-B-24-R	Navigation and anti-collision lights – 24V _{DC}
11-1280-C-12-L	Navigation, position, and anti-collision lights – 12V _{DC}
11-1280-C-12-R	Navigation, position, and anti-collision lights – 12V _{DC}
11-1280-C-24-L	Navigation, position, and anti-collision lights – 24V _{DC}
11-1280-C-24-R	Navigation, position, and anti-collision lights – 24V _{DC}

2 Specifications

Operational Voltage: Separate 14 & 28 V_{DC} Systems
Position/Navigation Current: 0.8 A at 14 V, 0.4 A at 28 V
Strobe Average Current: 0.6 A at 14 V, 0.4 A at 28 V
Strobe Peak Current: 4.8 A at 14 V for 0.2 seconds
 3.0 A at 28 V for 0.2 seconds

3 Limitations

3.1 Equipment Limitations

3.1.1 Mounting bracket P/N 01-1082 must be used to install the lights to the mounting surface as shown in Photo 4-1.

3.2 Airworthiness Limitations

- 3.2.1 Aircraft for which type certificate was applied for between April 1, 1957 and August 11, 1971:
The anti-collision system must produce a minimum of 100 effective candelas in Aviation Red or White, 360° around the vertical axis, 30° above and below the horizontal plane.
- 3.2.2 Aircraft for which type certificate was applied for after August 11, 1971:
The anti-collision system must produce a minimum of 400 effective candelas in Aviation Red or White, 360° around the vertical axis, 30° above and below the horizontal plane.
- 3.2.3 Rotorcraft for which type certificate was applied for after February 5, 1976:
The anti-collision system must produce a minimum of 150 effective candelas in Aviation Red, 360° around the vertical axis, 30° above and below the horizontal plane.

3.3 Instructions for Continued Airworthiness

- 3.3.1 The Pulsar NS series LED navigation and anti-collision light assembly is designed with 4 forward navigation LEDs, 2 rear position LEDs (11-1280-C-()-() only), and 18 LEDs mounted beneath the anti-collision lens (11-1280-B-()-() and 11-1280-C-()-()). Should any one LED fail, the unit must be replaced. View LEDs with welding goggles for eye safety.

3.4 Installation Procedures

- 3.4.1 Refer to Table 1-1 and ensure that the correct part number is installed per aircraft voltage
- 3.4.2 The installation procedure described in the following text is for a single light installation, but the procedure is identical for multiple light installations. Part numbers include -12 for 12 V_{DC}, -24 for 24 V_{DC}, -L for left, -R for right. Ensure that the proper part number is installed on the correct side of the aircraft.
- 3.4.3 If necessary, print out the installation template, Photo 4-2 on page 6 of this document. Set up the printer driver to NOT use Page Scaling so the printer will replicate the template to the proper 1:1 scale. Verify proper scaling by placing the included 'Y' Mounting Bracket over the printout to ensure a 1:1 fit.
- 3.4.4 By design, the 'Y' Mounting Bracket locks into the NS product body.
- 3.4.5 Attach the template to the wingtip (mounting) position and mark the screw and wire hole locations. The bracket will match existing mounting holes for most legacy installations.
- 3.4.6 Mount the bracket using three 6-32 100 degree countersunk screws. Ensure that the mounting bracket is grounded to structure via the mounting screws. If necessary, route a ground strap from one mounting screw to structure ground. Proper chassis ground is required for protection from direct lightning or ESD events.
- 3.4.7 Connect the red wire to switched power for the position lights, connect the yellow wire to switched power for the strobe lights, connect the black wire to system ground via the shield on the shielded cable or via a dedicated ground wire that runs to the aircraft ground bus at or near the instrument panel.
- 3.4.8 Connect the green wire to the synchronization wire from the other installed light(s). **WARNING:** Do not connect the strobe power wire to a Xenon strobe power pack. This can damage the light and **voids the warranty.**
- 3.4.9 Attach the light to the mounting bracket and anchor in place with the 8-32 hex head set screw (provided) that inserts into the rear of the light.
- 3.4.10 Update aircraft records per 14CFR 43.9

4 Installation and Wiring Diagrams

4.1 Mounting Diagram

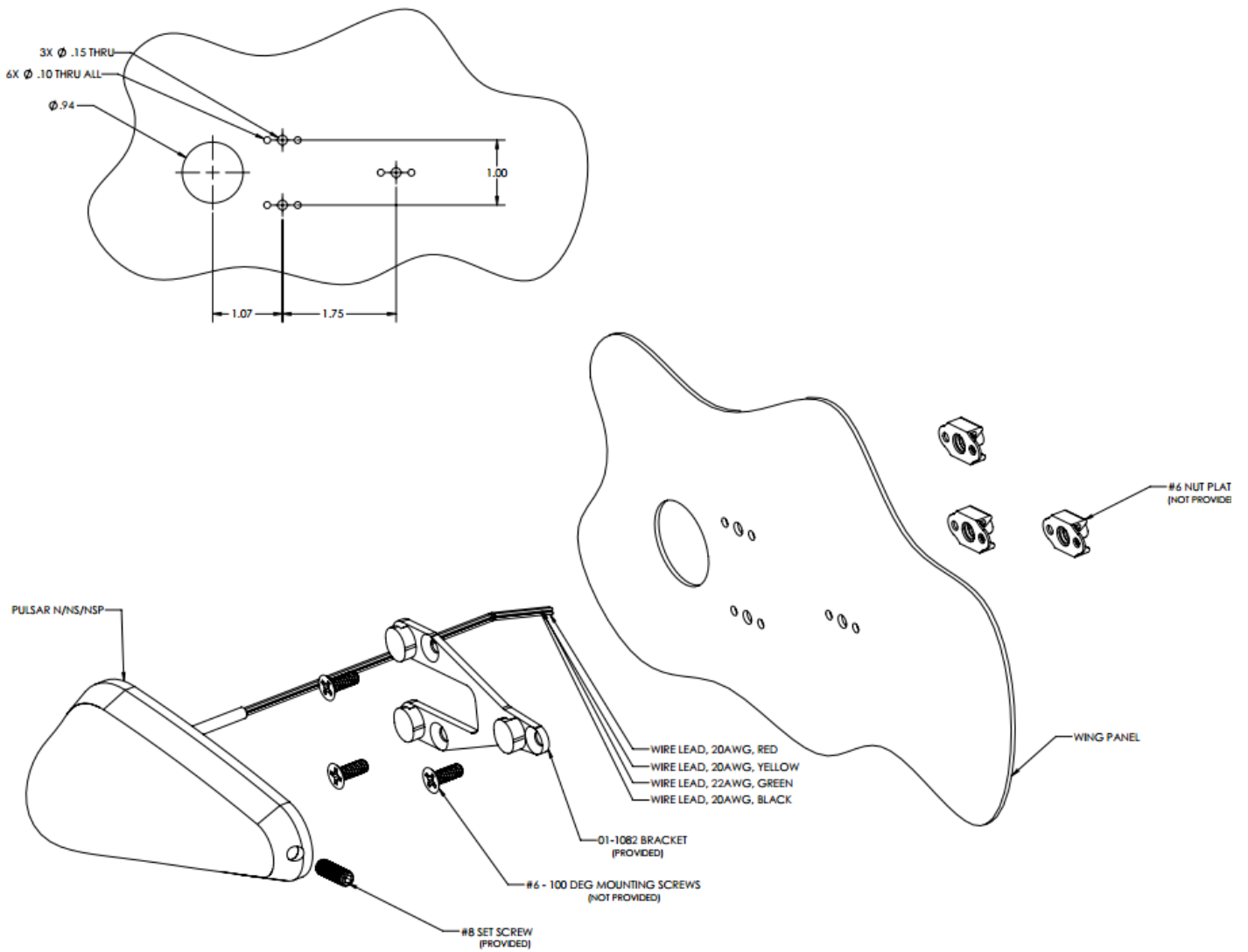

Photo 4-1

4.2 Installation Template

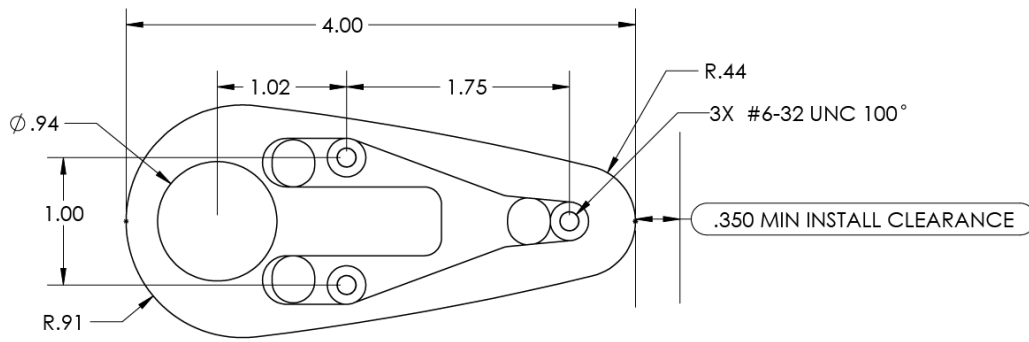

Photo 4-2

4.3 Wiring Diagram

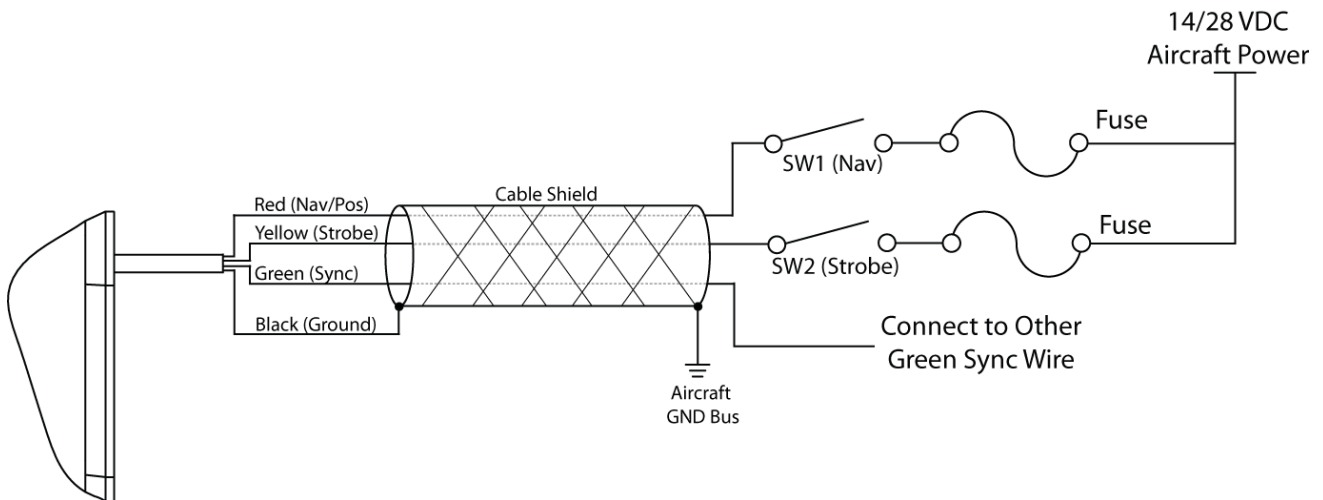

Photo 4-3

WARNING: Do not connect the strobe power wire to a Xenon strobe power pack. This will damage the light and voids the warranty.

4.4 Fuse Selection

4.4.1 Refer to AC 43.13 §4 for additional guidance or wire size and circuit breaker recommendations

Wire AN gauge copper	Circuit breaker amp.	Fuse amp.
22	5	5
20	7.5	5
18	10	10
16	15	10
14	20	15
12	30	20
10	40	30
8	50	50
6	80	70
4	100	70
2	125	100
1		150
0		150

Basis of chart:
(1) Wire bundles in 135 °F. ambient and altitudes up to 30,000 feet.
(2) Wire bundles of 15 or more wires, with wires carrying no more than 20 percent of the total current carrying capacity of the bundle as given in Specification MIL-W-5088 (ASG).
(3) Protectors in 75 to 85 °F. ambient.
(4) Copper wire Specification MIL-W-5088.
(5) Circuit breakers to Specification MIL-C-5809 or equivalent.
(6) Fuses to Specification MIL-F-15160 or equivalent.

4.4.2 14V: Budget a 10 A fuse for the strobe function of a **pair of lights**

4.4.3 14V: Budget a 2 A fuse for a the Nav/Pos function of a **pair of lights**

4.4.4 28V: Budget a 5 A fuse for the strobe function of a **pair of lights**

4.4.5 28V: Budget a 2 A fuse for a the Nav/Pos function of a **pair of lights**